

(19)



Europäisches Patentamt
European Patent Office
Office européen des brevets



(11) EP 0 876 506 B1

(12)

EUROPEAN PATENT SPECIFICATION

(45) Date of publication and mention of the grant of the patent:
09.07.2003 Bulletin 2003/28

(51) Int Cl.7: C12Q 1/28, C12Q 1/54,
G01N 27/327

(21) Application number: 96940610.7

(86) International application number:
PCT/US96/18889

(22) Date of filing: 25.11.1996

(87) International publication number:
WO 97/022715 (26.06.1997 Gazette 1997/27)

(54) INTERFERENCE FREE BIOSENSOR

STÖRUNGSFREIER BIOSENSOR

BIOCAPTEUR EXEMPT D'INTERFERENCES

(84) Designated Contracting States:
AT BE CH DE ES FR GB IT LI NL

(30) Priority: 18.12.1995 US 563728

(43) Date of publication of application:
11.11.1998 Bulletin 1998/46

(73) Proprietor: Abbott Laboratories
Abbott Park, Illinois 60064-3500 (US)

(72) Inventors:
• HENNING, Timothy, P.
Vernon Hills, IL 60061 (US)
• SPRING, Thomas, G.
Highland Park, IL 60035 (US)

(74) Representative: Modiano, Guido, Dr.-Ing. et al
Modiano, Josif, Pisanty & Staub,
Baaderstrasse 3
80469 München (DE)

(56) References cited:
US-A- 5 231 028

• CHEMICAL ABSTRACTS, vol. 119, no. 4, issued 1993, July 26, (Columbus, Ohio, USA), E. CSOEREGI et al. "Carbon fibers as electrode materials for the construction of peroxidase-modified amperometric biosensors", page 859, no. 39 728u; & Anal. Chim. Acta 1993, 273(1-2), 59-70.

• CHEMICAL ABSTRACTS, vol. 102, no. 22, issued 1985, June 3, (Columbus, Ohio, USA), J. JASATTIS et al. "Acceleration of electrode processes by biocatalysts. 10. Macrokinetic characteristics of hydrogen peroxide reduction on rotating peroxidase graphite electrodes", page 568, no. 193 765j; & Liet. TSR Mokslu Akad. Darb., Ser. B 1984, (6), 34-40.
• CHEMICAL ABSTRACTS, vol. 116, no. 8, issued 1992, February 24, (Columbus, Ohio, USA), G. JOENSSON-PETTERSSON "Reagentless hydrogen peroxide and glucose sensors based on peroxidase immobilized on graphite electrode", page 1093, no. 75 321 c; & Electroanalysis (N.Y.) 1991, 3(8), 741-50.
• CHEMICAL ABSTRACTS, vol. 119, no. 17, issued 1993, October 25, (Columbus, Ohio, USA), J. MARCINKEVICIENE et al. "Biosensor strip-type glucose sensor", page 388, no. 176 849y; & Biosens. Bioelectron. 1993, 8(3-4), 209-12.
• CHEMICAL ABSTRACTS, vol. 119, no. 16, issued 1993, October 18 (Columbus, Ohio, USA), J. WANG et al. "In situ elimination of metal inhibitory effects using ligand-containing carbon paste enzyme electrodes", page 926, no. 173 169r; & Anal. Chem. 1993, 65(19), 2698-700.
• 'Encyclopedia of Polymer Science and Engineering', 1986, JOHN WILEY & SONS INC.

EP 0 876 506 B1

Note: Within nine months from the publication of the mention of the grant of the European patent, any person may give notice to the European Patent Office of opposition to the European patent granted. Notice of opposition shall be filed in a written reasoned statement. It shall not be deemed to have been filed until the opposition fee has been paid. (Art. 99(1) European Patent Convention).

DescriptionField of the Invention

5 [0001] The present disclosure is in the field of biosensors for the analysis of body fluids.

Background of the Invention

10 [0002] One method for measuring the concentration of glucose in blood is to cause a reaction between the glucose and the enzyme glucose oxidase. The reaction produces hydrogen peroxide, which can be electrochemically oxidized at positive potentials. The current produced by the oxidation of peroxide is measured and is proportional to the glucose concentration in the blood. A similar scheme may be used to measure other analytes of interest by selecting the appropriate enzyme that will produce hydrogen peroxide in proportion to the concentration of the analyte, e.g., lactate may be similarly measured using the enzyme lactate oxidase.

15 [0003] A long standing problem with these measurement techniques is that of interference from other substances. Blood may contain other components which can oxidize at the same potential as hydrogen peroxide; prevalent among these are urate and acetaminophen. As these or other interfering substances oxidize, the current resulting from their oxidation is added to and indistinguishable from the current resulting from the oxidation of the hydrogen peroxide. An error therefore results in the quantification of the peroxide and consequently the blood analyte.

20 [0004] Many methods have been tried to reduce or eliminate these interferences. Acetaminophen has been particularly difficult to eliminate because, unlike urate, acetaminophen is not charged. One methodology disclosed in the art (see, e.g., Sittampalam, G., and Wilson, G. S., Analytical Chemistry, 55:1608-1610, 1983, and Geise, R. J., et al, Biosensors and Bioelectronics, 6:151-160, 1991) has been to use one or more selectively permeable membranes to prevent the interfering substances from contacting the electrode, although this method is not effective at fully preventing interference.

25 [0005] An alternate method for preventing interference is disclosed in U.S. Patents 5,225,064 and 5,334,296. This method decreases the electrical potential of the reaction to a state where urate and acetaminophen are not oxidized. This may be accomplished by employing an enzyme that will reduce hydrogen peroxide, such as a form of peroxidase, in the electrode. In this type of system, the hydrogen peroxide reacts with the peroxidase, in which reaction the hydrogen peroxide is reduced and the peroxidase oxidizes. If the peroxidase is in intimate contact with an electrode's surface, the peroxidase can be reduced at the electrode by imposing an electrical potential. The magnitude of the current required to reduce the peroxidase is proportional to the concentration of the hydrogen peroxide and hence proportional to the concentration of glucose or other analyte of interest. Moreover, the reactions occur at potentials at which urate and acetaminophen do not oxidize and therefore do not interfere.

35 [0006] The art recognizes the use of horseradish peroxidase or fungal peroxidase physically adsorbed to a gold or carbon surface in attempts to prevent interference (see, e.g., U.S. Patents 5,225,064 and 5,334,296; Ho, W. O., et al, J. Electroanal. Chem., 351:187-197, 1993; Wollenberger, U., et al, Bioelectrochemistry and Bioenergetics, 26:287-296, 1991; Csoregi, E., et al, Anal. Chem. 66:3604-3610, 1994). However these reports indicate that such use has yielded unsatisfactory results as the magnitude of the electric currents forming the signals in these applications are quite small and the linearity is poor at high peroxide concentrations.

40 [0007] There is great utility, therefore, in the development of an electrode system in which hydrogen peroxide reacts in a measurable way, generating signal currents of usable magnitudes and that are linear to high concentrations, yet which are not subject to interference caused by the oxidation of interfering substances such as urate and acetaminophen.

45 [0008] As further background art, Csoregi, E. et al., Analytica Chimica Acta, 273 (1993) 59-70, disclose the use of carbon fibers covalently linked to peroxidase as electrode material in a biosensor for measuring an analyte. U.S. Patent No. 5,231,028 discloses enzyme electrodes which contain platinized microparticles of carbon to which the enzyme may be covalently linked.

Brief Description of the Figures**[0009]**

55 Figure 1 shows an analytical electrode embodying the interference free biosensor of the invention.

Summary of the Invention

[0010] The present invention provides a composition comprising microparticles covalently linked to peroxidase,

wherein said microparticles are selected from the group consisting of microparticles of native carbon, microparticles of derivatized carbon and microparticles of polypyrrole or polyaniline. Preferably, the microparticle carbon is native microparticle carbon conjugated to microperoxidase via a bifunctional reagent.

5 [0011] The present invention also provides an electrode for the determination of an analyte in a sample comprising microparticles covalently linked to peroxidase to form a conjugate, wherein said microparticles are selected from the group consisting of microparticles of native carbon, microparticles of derivatized carbon and microparticles of polypyrrole or polyaniline, said conjugate confined to an electrically conductive surface. The preferred electrode comprises native microparticle carbon covalently linked to microperoxidase in a resin matrix.

10 Detailed Description of the Invention

[0012] Embodiments of the invention generally comprise an electrode used to electrochemically measure the concentration of an analyte of interest in a solution. The biosensor or electrode includes a peroxidase enzyme covalently bound to microparticle carbon and retained in a matrix in intimate contact with the electrode. As used herein, the term
15 "microparticle carbon" refers to fine particles of carbon and polypyrrole or polyaniline. Microparticle carbon in a variety of forms are known in the art and may be readily obtained from commercial vendors. For ease of use and handling, it is preferred that the microparticle carbon be less than 1000 nanometers (1 micron) in diameter, preferably in the range of 5-50 nm. In the experiments described below, a fine (30 nm) particle carbon (Vulcan XC72R; E-TEK, Natick MA) is used.

20 [0013] The microparticle carbon can be used in its native state ("native") or various functional groups can be attached to the carbon ("derivatized") following techniques known in the art. For derivatized carbon, the carbon microparticle is reacted with a bifunctional reagent, preferably with a bifunctional agent having amine-containing function groups. As bifunctional reagents are available having a wide variety linkers of differing lengths between the two functional ends, one can easily and rapidly determine those reagents which are suitable for use with a variety of enzymes and for a
25 variety of applications. The resulting derivatized carbon particles can be immediately coupled to the enzyme or can be stored prior to enzyme coupling.

[0014] The derivatized or native particles are covalently attached to the enzyme, again following techniques known in the art, and as described in more detail below.

30 [0015] Peroxidase of any origin is useful in the interference free biosensor of the invention. Peroxidase is readily obtained following techniques known in the art, or alternatively, may be purchased from commercial vendors. In a preferred embodiment, the peroxidase is microperoxidase such as described European Patent Publication 0 195 320.

[0016] As microparticle carbon with attached enzyme cannot by itself be readily used for the detection of an analyte of interest, the carbon should be physically confined in such a manner that the analyte may be brought into contact with the carbon:enzyme conjugate. Any of the confinement means known in the art of e.g., gold:peroxidase conjugates,
35 are suitable for use in the present invention as well. For example, by the use of semi- or selectively-permeable membranes, the carbon can be physically restrained while allowing the analyte of interest to come into intimate contact with the peroxidase enzyme. In a preferred embodiment, the microparticle carbon:enzyme conjugate is used for construction of an electrode. In this particular embodiment, the microparticle carbon:enzyme conjugate is confined to an electrically conductive surface in order to form an electrode. Of the many ways of confining the carbon:enzyme microparticle to a
40 surface which are known in the art, the procedure described in International Patent Publication WO 95/22057 is preferred. The method described therein incorporates the particles into a resin matrix (also referred to as "paint") and has the benefits of being water based to preserve enzyme activity. It also yields a liquid, facilitating dispensing and easing the manufacturing of electrodes. As disclosed therein, the liquid resin with the contained carbon particles dries to form a water insoluble film which is compatible with blood.

45 [0017] The enzyme:microparticle carbon of the invention is useful in any application where the catalytic properties of peroxidase prove beneficial. Significantly, the enzyme:microparticle carbon of the invention provides a composition which is essentially free of interference from compounds which normally interfere with peroxide determinations. Thus the enzyme:microparticle carbon-containing compositions of the invention can be used in instrument based systems (in vitro) or in devices for the direct measurement of blood analytes in vivo.

50 Example 1 - Covalent coupling of microperoxidase to carbon particles

[0018] In this experiment, native and two forms of derivatized carbon particles are covalently coupled to microperoxidase.

55 [0019] The first form of derivatized carbon utilizes the functional group ethylenediamine (Aldrich, Milwaukee WI) attached to carbon by mixing 100 mg of carbon with 27 mg of ethylenediamine in 5 mL of a 50 mM 2[N-Morpholino]ethanesulfonic Acid (MES) (Sigma, St. Louis MO) buffer at pH 5.5. 50 mg of 1-(3-Dimethylaminopropyl)-3-ethylcarbodiimide hydrochloride (EDC) (Pierce, Rockford IL) is then added to initiate the coupling and allowed to react for 1 hour.

The derivatized carbon is removed by centrifugation and washed three times with water.

[0020] In a second form of derivatized carbon, a poly(oxyalkylene)diamine (JEFFAMINE® ED-600; Texaco, Houston TX) is employed as the functional reagent and is attached to carbon by mixing 100 mg of carbon with 240 mg of the diamine in 5 mL of a 4% pyridine/water solution at pH 5.5. 4 mg of EDC is then added to initiate the coupling and allowed to react overnight. The derivatized carbon is then removed by centrifugation and washed three times with water.

[0021] The peroxidase enzyme is covalently coupled to the native or derivatized microparticle carbon using EDC. 100 mg of carbon is mixed with 20 mg of the peroxidase enzyme (for example, MP-11 microperoxidase from Sigma Chemical, St. Louis, MO) in 5 mL of a 50 mM MES buffer, pH 5.5. Alternatively, and preferably, the buffer can be 4% pyridine/water solution at pH 5.5. 10 mg of EDC is added and the solution is mixed for 1 hour. The carbon with covalently attached peroxidase enzyme is removed by centrifugation and washed with water. The carbon with attached enzyme is stored wet.

[0022] To provide a comparison to covalent coupling, enzyme adsorption is done in a solution of 50 mM sodium phosphate, 1 mM EDTA, 100 mM sodium chloride, and 0.05% antimicrobial (Kathon CG; Rohm and Haas, Philadelphia PA) solution at a pH of 7.5. This solution is referred to as PESK 7.5. 125 mg of carbon is mixed with 25 mg of the enzyme in 5 mL of PESK 7.5 overnight. The carbon is then removed by centrifugation and washed three times with PESK 7.5.

Example 2 - Preparation of the Paint

[0023] A resin matrix for retaining the carbon on a conductive surface, termed F133 Resin, is made by combining the following weights of each component:

Joncryl 537 (Johnson Wax, Racine WI)	65.04 mg
NH ₄ OH, 10% in water	8.91 mg
2-Ethoxy-ethanol (Aldrich, Milwaukee WI)	20.94 mg
Dibutyl Phthalate (Fluka, Ronkonkoma, NY)	7.13 mg
Surfynol 104H (Air Products, Allentown, PA)	2.50 mg
Surfynol 695 (Air Products)	5.0 mg
Acrysol 275 (Rohm and Haas, Philadelphia, PA)	30.6 mg

[0024] 72 mg of the resin, a liquid, is then combined with 160 mg of the carbon:enzyme conjugate compacted in the wet state, 262 mg of 0.085 M trehalose (Sigma, St. Louis, MO) in water. A vigorous mixing of the three components is done using an amalgamator (WIG-L-BUG; Crescent Dental Co., Lyons IL) for 3 minutes, forming a liquid suspension. This suspension or paint may then be applied to an electrode.

Example 3 - Electrode construction

[0025] The carbon:enzyme conjugates are utilized in an analytical electrode of the type described in International Patent Publication WO 95/22057.

[0026] Briefly, an analytical electrode assembly for testing the carbon:enzyme conjugates of the invention is shown in Figure 1. Electrode assembly 10 consists of one or more (in this figure, four) biosensors 12 mounted on a polyester sheet 32. The biosensors 12 are constructed by printing silver/silver chloride (Acheson SS24540) electrical connections 20 on the polyester sheet 32. At the location for electrical contact with the instrument 21 as well as the terminus of the electrical connection 20, an electrically conducting trace is formed by screen printing of carbon ink (Acheson 423SS) over the electrical connection 20. The carbon surface is masked by the application of a screen printed dielectric (Acheson ML 25208), leaving 0.013 cm² of carbon exposed for application of the paint at 12. 0.2 to 1.0 µl of carbon:enzyme conjugate paint is applied to the exposed surface of the carbon trace using a hand dispenser. Reference electrode 14 is printed using silver/silver chloride (Acheson SS24540). An additional counter electrode (not visible in Figure 1) is formed on face plate 18 on the side facing gasket 16. The counter electrode is printed with carbon as described above, however no paint is applied. Gasket 16 provides a flow channel 34 when sandwiched between polyester sheet 32 and front plate 18. Fluid may then flow over the biosensors 12, reference electrode 14, and the counter electrode (not shown) from entry port 24 exiting via exit port 26. Back plate 22 may be fastened to front plate 18 via a fastening means such as a nut 28 inserted through fastening hole 42 to bolt 30. Optionally, alignment means may be provided to ensure proper registry of the components via holes 44 and pins 46.

Example 4 - Demonstration of sensitivity

[0027]

- 5 a. Several electrodes are fabricated as described in Examples 1 through 3, utilizing different enzymes (horseradish peroxidase, soybean peroxidase, and microperoxidase), different carbon attachment methods (adsorption or covalent coupling), and different carbon treatments (native, ethylenediamine, or JEFFAMINE ED-600). A test solution of about 0.1 mM hydrogen peroxide at 37 °C is passed over the carbon trace, the reference electrode, and the counter electrode. A fixed electrical potential of 100 mV is applied to the electrode, and the resulting electrical current is recorded for various electrode types using a standard three electrode circuit. The measured currents for various combinations of enzyme, carbon attachment technique, and carbon treatment are as follows:

Enzyme	Carbon Attachment	Carbon Treatment	Current (nA)
Horseradish Peroxidase	Adsorption	None	-34
Horseradish Peroxidase	Covalent	Ethylene-diamine	-187
Horseradish Peroxidase	Covalent	JEFFAMINE	-324
Soybean Peroxidase	Covalent	Ethylene-diamine	-407
Soybean Peroxidase	Covalent	JEFFAMINE	-442
Microperoxidase	Adsorption	None	-46
Microperoxidase	Covalent	None	-1023

15 As apparent from the foregoing, covalently attached microperoxidase shows much larger currents than the conventional method of adsorption. Covalently attached microperoxidase (MP-11, Sigma, St. Louis MO) yields much larger currents than other peroxidase enzymes such as horseradish peroxidase (Type II, Sigma) and soybean peroxidase (Enzymol International, Inc., Bexley OH).

- 20 b. Potassium ferricyanide also reduces in a reversible reaction that is similar to peroxidase. It is well recognized in the art, see, e.g., Csoregi, E., et al, that when equal concentrations of peroxide and ferricyanide are employed, the current produced from the peroxidase is 30-60 X less than the current produced from the ferricyanide. To assess the sensitivity of the present invention, the current resulting from the reduction of peroxide at the present electrodes is compared to the current resulting from the reduction of potassium ferricyanide. Hydrogen peroxide and ferricyanide at substantially equal concentrations of about 0.05 mM at about 37 °C are passed over an embodiment of the electrode described here having microperoxidase covalently coupled to native carbon. Surprisingly, the current for peroxide reduction was twice that as for ferricyanide reduction (see following table).

Analyte	Applied Potential (mV)	Current (nA)
Hydrogen Peroxide	100	-147
Ferricyanide	0	-70

40 [0028] Because the peroxide reduction involves two electrons as opposed to one for ferricyanide, a signal produced by the present invention which is twice that produced by ferricyanide indicates extremely fast electron transfer from the carbon to the microperoxidase enzyme (at least as fast as that for the reversible Ferri/Ferrocyanide reaction). This has never been achieved before, and demonstrates the sensitivity of the invention.

Example 5 - Demonstration of Linearity

50 [0029] Electrodes are made with soybean and horseradish peroxidase covalently coupled to ethylenediamine derivatized carbon and microperoxidase covalently coupled to native carbon. The response of the electrodes to varying levels of hydrogen peroxide at about 37 °C and an electrode potential of 100 mV is measured, with the following results.

EP 0 876 506 B1

Enzyme	Current (nA) 0.005 mM H ₂ O ₂	Current (nA) 0.010 mM H ₂ O ₂	Current (nA) 0.100 mM H ₂ O ₂	Current (nA) 0.300 mM H ₂ O ₂
Soybean Peroxidase	-70	-114	-407	---
Horseradish Peroxidase	-69	-102	-257	---
Microperoxidase	-13	-27	-237	-669

[0030] As can be seen, neither soybean nor horseradish peroxidase are linear over the range tested. Readings at higher concentrations are not taken as the response is significantly diminished and thus the information is not informative. On the other hand, microperoxidase demonstrates linearity to at least 0.3 mM hydrogen peroxide.

[0031] In the literature to date, horseradish or fungal peroxidase have been favored over microperoxidase for use in the detection of peroxide. However, embodiments of this invention utilizing microperoxidase far exceed applications with other peroxidase enzymes in not only signal size but also in linearity.

Example 6 - Measurement of glucose concentrations

[0032] In this example, glucose is measured using a commercial instrument (Nova Biomedical Stat Profile 10) in which the paint of the present invention is used in commercial electrodes supplied by the manufacturer.

[0033] Microperoxidase is covalently attached to native carbon as described in Examples 1 and a paint is made as described in Example 2. The paint is applied to the center of the interior surface of a Nova Biomedical glucose enzyme cap in such a way that the paint is aligned with the platinum working electrode of the electrode body. The paint is allowed to dry and the cap is then placed on the glucose electrode body. The control electrode is an unmodified glucose electrode, i.e., as supplied by the manufacturer, and is operated in accordance with the manufacturer's instructions. The modified electrode is placed in a flow cell and glucose solutions having varying levels of interfering substances are passed over the electrode, with flow stopped for measurements. The current is measured using a potentiostat, with about 100 mV potential applied. The glucose level is kept constant at about 2 mM at a temperature of about 37 °C to simulate a hypoglycemic diabetic sample. Acetaminophen is varied up to the toxic limit of 2 mM. The percentage change in signal of the electrode in the absence and presence of acetaminophen is quantified, with the results shown below.

%Change in Glucose Signal vs Acetaminophen Concentration. 2 mM Glucose solution.

5

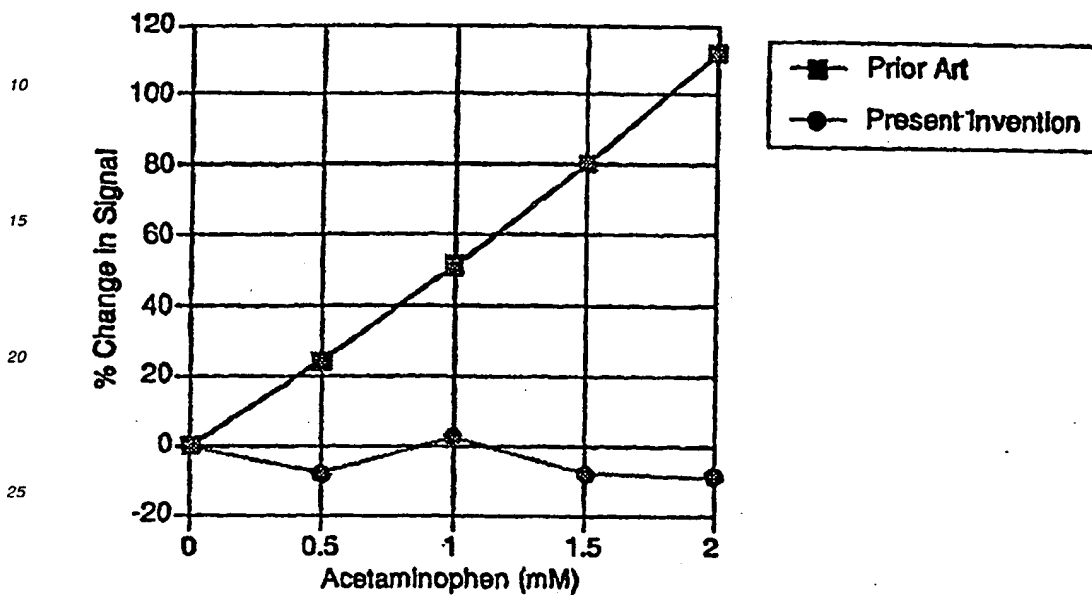

30

[0034] The results indicate that there is essentially no effect of acetaminophen on the glucose measurement of the electrode embodiment described here.

Example 7 - Measurement of lactate concentration

35

[0035] An experiment similar to that of Example 6 is conducted using a Nova Biomedical Lactate enzyme cap. As lactate is found in lower concentrations in blood than glucose, a 0.3 mM lactate solution is used. Again, as shown below, the utilization of the microperoxidase of the present invention eliminates interference due to acetaminophen on lactate measurement.

40

45

50

55

% Change in Lactate Signal vs Acetaminophen Concentration. 0.3 mM Lactate Solution.

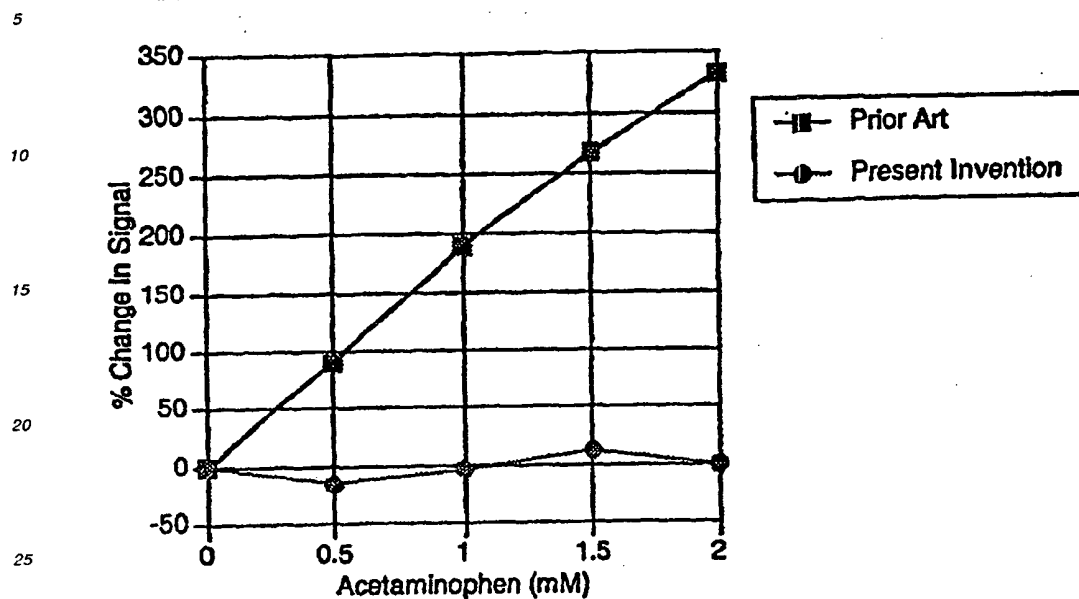

Example 8 - Comparison of Microperoxidase to Porphyrins

30

[0036] It is known in the art that porphyrin can act as a catalyst. Because microperoxidase is essentially a short peptide chain of 11 amino acids which is covalently attached to a porphyrin ring, and thus many similarities exist in chemical structure between porphyrins and microperoxidase, the following experiment assesses the necessity of the peptide chain in the catalytic reduction of peroxide.

35

[0037] Cobalt is inserted into Protoporphyrin IX dimethylester (Sigma) with the following procedure. 50mg of porphyrin is dissolved in 25mL of DMF in a 100mL round bottomed flask. 50 mg of the cobalt chloride (Sigma) is added and refluxed until the florescence is quenched. The solution is then cooled and cold water is added to recrystallize the cobalt porphyrin. After washing and drying, cobalt porphyrin is adsorbed to 250 mg of wet carbon. The adsorption is done by mixing 10 mg of dry porphyrin with carbon in 5 mL of chloroform. After removing chloroform by washing with acetone and water, the cobalt porphyrin is made into a paint by mixing about 160 mg of carbon:adsorbed porphyrin, 72 mg of F133 resin, and 262 mg of 0.085 M trehalose in water. The paint is dispensed on the screen printed electrode described in Example 3. The reduction of 0.1 mM hydrogen peroxide is recorded for cobalt porphyrin electrodes and microperoxidase (covalently linked to native carbon) electrodes at different potentials.

45

50

55

REDUCTION OF 0.1 mM HYDROGEN
PEROXIDE AS A FUNCTION OF POTENTIAL

5

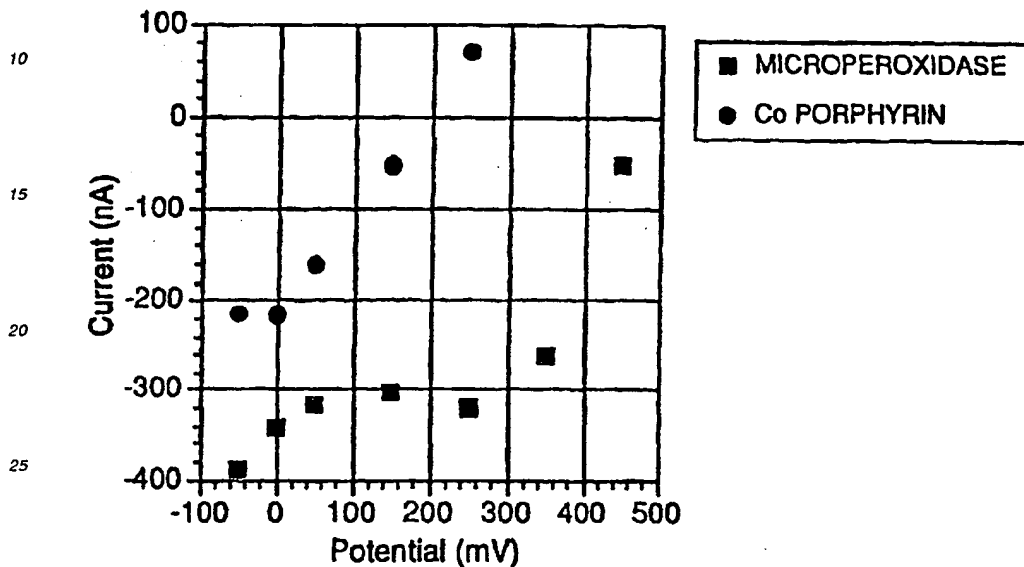

30

[0038] These results show that a microperoxidase containing paint of the present invention is capable of reducing peroxide at potentials approximately 400 mV more easily than cobalt porphyrin. This indicates that microperoxidase performs significantly better than porphyrin in the catalytic reduction of peroxide.

35

Example 9 - Synthesis of Alternate Microperoxidase Enzymes

40

[0039] The following experiment is designed to explore the necessity of iron to the catalytic property of microperoxidase. The results indicate that the metal moiety is necessary for catalytic activity, and, surprisingly, activity is retained when the native iron is removed and replaced with other metals.

45

a. Iron is removed from microperoxidase by adding 800 mg of iron sulfate in 4mL of concentrated HCl to 2000 mg of enzyme dissolved in 14mL of glacial acetic acid. This reaction mixture is left stirring under nitrogen for 10 minutes during which the maroon color of the solution turned purple. Acetone is added to the solution until the microperoxidase precipitates. This solid is then collected, washed by centrifugation with acetone, and dried.

50

b. To insert the various metals, 20 mg of the microperoxidase from Example 9a (referred to hereafter as "deironated" peroxidase) is dissolved in 4 mL of a 1:3 pyridine:acetic acid solution. The solution is heated to 80 °C under nitrogen and 20 mg of metal (e.g., iron, zinc, copper, nickel) in the form of the sulfate or chloride salt, is added in 1mL of water. The mixture is reacted under nitrogen at 80 °C for 10min. followed by cooling in air for 10min. Acetone is added to precipitate the microperoxidase, and the solids are washed with acetone.

55

[0040] Each microperoxidase containing a different metal is tested for activity prior to covalent coupling to carbon. The activity is measured by observing the rate of formation of the quinoneimine dye from 4-aminoantipyrine and 2-hydroxy-3,5-dichlorobenzene sulfonic acid at 550 nm in the presence of an excess of hydrogen peroxide. The following relative activity results are determined.

Microperoxidase	Activity ($\mu\text{g/mL}$)
Untreated	3.79

(continued)

Microperoxidase	Activity ($\mu\text{g/mL}$)
"De-ironated"	0.008
Iron	2.848
Zinc	1.694
Copper	0.128
Nickel	1.78

[0041] The results indicate an approximately 25% loss in activity following removal and replacement of iron. The zinc and nickel microperoxidases, show approximately a 50% loss in activity. Copper microperoxidase is not very active.

[0042] The microperoxidase enzymes containing different metal ions are covalently coupled to native carbon using the procedure described in Example 1. Paints are prepared using about 160 mg of carbon:enzyme conjugate, 72 mg of F133 resin, and 262 mg of 0.085 M trehalose in water, after which it is dispensed on carbon traces, as described in Example 3, for testing. The electrodes are tested for the reduction of hydrogen peroxide at 100 mV.

Microperoxidase	Current (nA)
Iron (untreated)	-800
Nickel	-560
Zinc	-190
Copper	-20

[0043] These results show that microperoxidase can be modified by insertion of a different metal ion and used in a sensor to detect peroxide.

[0044] The present invention has been described generally as well as with reference to preferred embodiments. One of skill in the art will readily appreciate that changes, alterations or modifications can be made to these preferred embodiments without departing from the true scope of the invention as defined by the appended claims.

Claims

1. A composition comprising microparticles covalently linked to peroxidase, wherein said microparticles are selected from the group consisting of microparticles of native carbon, microparticles of derivatized carbon and microparticles of polypyrrole or polyaniline.
2. The composition of Claim 1 wherein the microparticles consist of native carbon.
3. The composition of Claim 1 wherein the microparticles consist of derivatized carbon that has been derivatized with a bifunctional reagent.
4. The composition of Claim 3 wherein the bifunctional reagent is a diamine.
5. The composition of Claim 4 wherein the diamine is a poly(oxyalkylene)diamine.
6. The composition of Claim 1 wherein the peroxidase is microperoxidase.
7. The composition of Claim 6 wherein the microparticles consist of native carbon.
8. The composition of Claim 1 wherein the metal moiety of the peroxidase is modified to contain a member selected from the group consisting of iron, nickel and zinc.
9. The composition of Claim 1 further comprising a resin matrix.

10. An electrode for the determination of an analyte in a sample comprising:
- 5 microparticles covalently linked to peroxidase to form a conjugate, wherein said microparticles are selected from the group consisting of microparticles of native carbon, microparticles of derivatized carbon and microparticles of polypyrrole or polyaniline, said conjugate confined to an electrically conductive surface.
11. The electrode of Claim 10 wherein the microparticles consist of native carbon.
12. The electrode of Claim 11 wherein the peroxidase is microperoxidase.
- 10 13. The electrode of Claim 12 wherein the conjugate of microparticle and peroxidase is confined in a resin matrix.
14. The electrode of Claim 10 wherein the microparticles consist of derivatized carbon that has been derivatized with a bifunctional reagent.
- 15 15. A method of measuring an analyte of interest in a test sample, said method comprising the steps of (1) contacting the sample with microparticles covalently linked to peroxidase to form a conjugate, wherein said microparticles are selected from the group consisting of microparticles of native carbon, microparticles of derivatized carbon and microparticles of polypyrrole or polyaniline, and wherein the conjugate of microparticle and peroxidase is confined to an electrically conductive surface, and (2) detecting change in electrical signal as a quantitative or qualitative measure of the amount of analyte in the sample.
- 20 16. The method of Claim 15 wherein the microparticles consist of native carbon.
- 25 17. The method of Claim 16 wherein the peroxidase is microperoxidase.
18. The electrode of Claim 15 wherein the conjugate of microparticle and peroxidase is confined in a resin matrix.
- 30 19. The electrode of Claim 15 wherein the analyte is glucose or lactose.
20. The electrode of Claim 15 wherein the microparticles consist of derivatized carbon that has been derivatized with a bifunctional reagent.

35 **Patentansprüche**

- 40 1. Eine Zusammensetzung, die Mikropartikel umfaßt, die kovalent an Peroxidase gebunden sind, worin die Mikropartikel gewählt sind aus der Gruppe bestehend aus Mikropartikeln aus natürlichem Kohlenstoff, Mikropartikeln aus derivatisiertem Kohlenstoff und Mikropartikeln aus Polypyrrol oder Polyanilin.
- 45 2. Die Zusammensetzung von Anspruch 1, worin die Mikropartikel aus natürlichem Kohlenstoff bestehen.
3. Die Zusammensetzung von Anspruch 1, worin die Mikropartikel aus derivatisiertem Kohlenstoff bestehen, der mit einem bifunktionalen Reagenz derivatisiert wurde.
- 50 4. Die Zusammensetzung von Anspruch 3, worin das bifunktionale Reagenz ein Diamin ist.
5. Die Zusammensetzung von Anspruch 4, worin das Diamin ein Poly(oxyalkylen)diamin ist.
- 55 6. Die Zusammensetzung von Anspruch 1, worin die Peroxidase Mikroperoxidase ist.
7. Die Zusammensetzung von Anspruch 6, worin die Mikropartikel aus natürlichem Kohlenstoff bestehen.
8. Die Zusammensetzung von Anspruch 1, worin der Metallanteil der Peroxidase modifiziert ist, um ein Glied zu enthalten, das gewählt ist aus der Gruppe bestehend aus Eisen, Nickel und Zink.
9. Die Zusammensetzung von Anspruch 1, die weiterhin eine Harz-Matrix umfaßt.

EP 0 876 506 B1

10. Eine Elektrode für die Bestimmung eines Analyten in einer Probe, die folgendes umfaßt:

5 Mikropartikel, die kovalent an Peroxidase gebunden sind, um ein Konjugat zu bilden, worin die Mikropartikel gewählt sind aus der Gruppe bestehend aus Mikropartikeln aus natürlichem Kohlenstoff, Mikropartikeln aus derivatisiertem Kohlenstoff und Mikropartikeln aus Polypyrrol oder Polyanilin, wobei das Konjugat begrenzt ist auf eine elektrisch leitende Oberfläche.

11. Die Elektrode von Anspruch 10, worin die Mikropartikel aus natürlichem Kohlenstoff bestehen.

10 12. Die Elektrode von Anspruch 11, worin die Peroxidase Mikroperoxidase ist.

13. Die Elektrode von Anspruch 12, worin das Konjugat aus Mikropartikel und Peroxidase in einer Harz-Matrix begrenzt ist.

15 14. Die Elektrode von Anspruch 10, worin die Mikropartikel aus derivatisiertem Kohlenstoff bestehen, der mit einem bifunktionalen Reagenz derivatisiert wurde.

20 15. Ein Verfahren zum Messen eines Analyten von Interesse in einer Testprobe, wobei das Verfahren die folgenden Schritte umfaßt: (1) In-Kontakt-bringen der Probe mit Mikropartikeln, die kovalent an Peroxidase gebunden sind, um ein Konjugat zu bilden, worin die Mikropartikel gewählt sind aus der Gruppe bestehend aus Mikropartikeln aus natürlichem Kohlenstoff, Mikropartikeln aus derivatisiertem Kohlenstoff und Mikropartikeln aus Polypyrrol oder Polyanilin, und worin das Konjugat aus Mikropartikel und Peroxidase begrenzt ist auf eine elektrisch leitende Oberfläche, und (2) Detektieren einer Änderung im elektrischen Signal als ein quantitatives oder qualitatives Maß der Menge des Analyten in der Probe.

25 16. Das Verfahren von Anspruch 15, worin die Mikropartikel aus natürlichem Kohlenstoff bestehen.

17. Das Verfahren von Anspruch 16, worin die Peroxidase Mikroperoxidase ist.

30 18. Die Elektrode von Anspruch 15, worin das Konjugat aus Mikropartikel und Peroxidase in einer Harz-Matrix begrenzt ist.

19. Die Elektrode von Anspruch 15, worin der Analyt Glucose oder Lactose ist.

35 20. Die Elektrode von Anspruch 15, worin die Mikropartikel aus derivatisiertem Kohlenstoff bestehen, der mit einem bifunktionalen Reagenz derivatisiert wurde.

Revendications

40 1. Composition comprenant des microparticules liées de façon covalente à de la peroxydase, dans laquelle lesdites microparticules sont choisies dans le groupe comprenant les microparticules de carbone natif, les microparticules de carbone dérivatisé et les microparticules de polypyrrole ou de polyaniline.

45 2. Composition selon la revendication 1, dans laquelle les microparticules consistent en du carbone natif.

3. Composition selon la revendication 1, dans laquelle les microparticules consistent en du carbone dérivatisé qui a été dérivatisé avec un réactif bifonctionnel.

50 4. Composition selon la revendication 3, dans laquelle le réactif bifonctionnel est une diamine.

5. Composition selon la revendication 4, dans laquelle la diamine est une poly(oxyalkylène)diamine.

55 6. Composition selon la revendication 1, dans laquelle la peroxydase est une microperoxydase.

7. Composition selon la revendication 6, dans laquelle les microparticules consistent en du carbone natif.

8. Composition selon la revendication 1, dans laquelle le groupe caractéristique métal de la peroxydase est modifié

pour contenir un membre choisi dans le groupe comprenant le fer, le nickel et le zinc.

9. Composition selon la revendication 1, comprenant en outre une matrice de résine.
- 5 10. Electrode pour le dosage d'un analyte dans un échantillon comprenant :
- des microparticules liées de façon covalente à de la peroxydase pour former un conjugué, dans laquelle les-
dites microparticules sont choisies dans le groupe comprenant les microparticules de carbone natif, les mi-
croparticules de carbone dérivatisé et les microparticules de polypyrrole ou de polyaniline, ledit conjugué étant
10 confiné à une surface conductrice.
11. Electrode selon la revendication 10, dans laquelle les microparticules consistent en du carbone natif.
12. Electrode selon la revendication 11, dans laquelle la peroxydase est une microperoxydase.
- 15 13. Electrode selon la revendication 12, dans laquelle le conjugué de microparticule et de peroxydase est confiné
dans une matrice de résine.
14. Electrode selon la revendication 10, dans laquelle les microparticules consistent en du carbone dérivatisé qui a
20 été dérivatisé avec un réactif bifonctionnel.
15. Procédé pour mesurer un analyte intéressant dans un échantillon pour essai, ledit procédé comprenant les étapes
consistant à (1) mettre en contact l'échantillon avec des microparticules liées de façon covalente à de la peroxydase
pour former un conjugué, dans lequel lesdites microparticules sont choisies dans le groupe comprenant les mi-
croparticules de carbone natif, les microparticules de carbone dérivé et les microparticules de polypyrrole ou de
25 polyaniline, et dans lequel le conjugué de microparticule et de peroxydase est confiné à une surface conductrice,
et (2) détecter la variation de signal électrique comme une mesure qualitative ou quantitative de la quantité d'ana-
lyte dans l'échantillon.
- 30 16. Procédé selon la revendication 15, dans lequel les microparticules consistent en du carbone natif.
17. Procédé selon la revendication 16, dans lequel la peroxydase est une microperoxydase.
18. Electrode selon la revendication 15, dans laquelle le conjugué de microparticule et de peroxydase est confiné
35 dans une matrice de résine.
19. Electrode selon la revendication 15, dans laquelle l'analyte est du glucose ou du lactose.
- 40 20. Electrode selon la revendication 15, dans laquelle les microparticules consistent en du carbone dérivatisé qui a
été dérivatisé avec un réactif bifonctionnel.

45

50

55

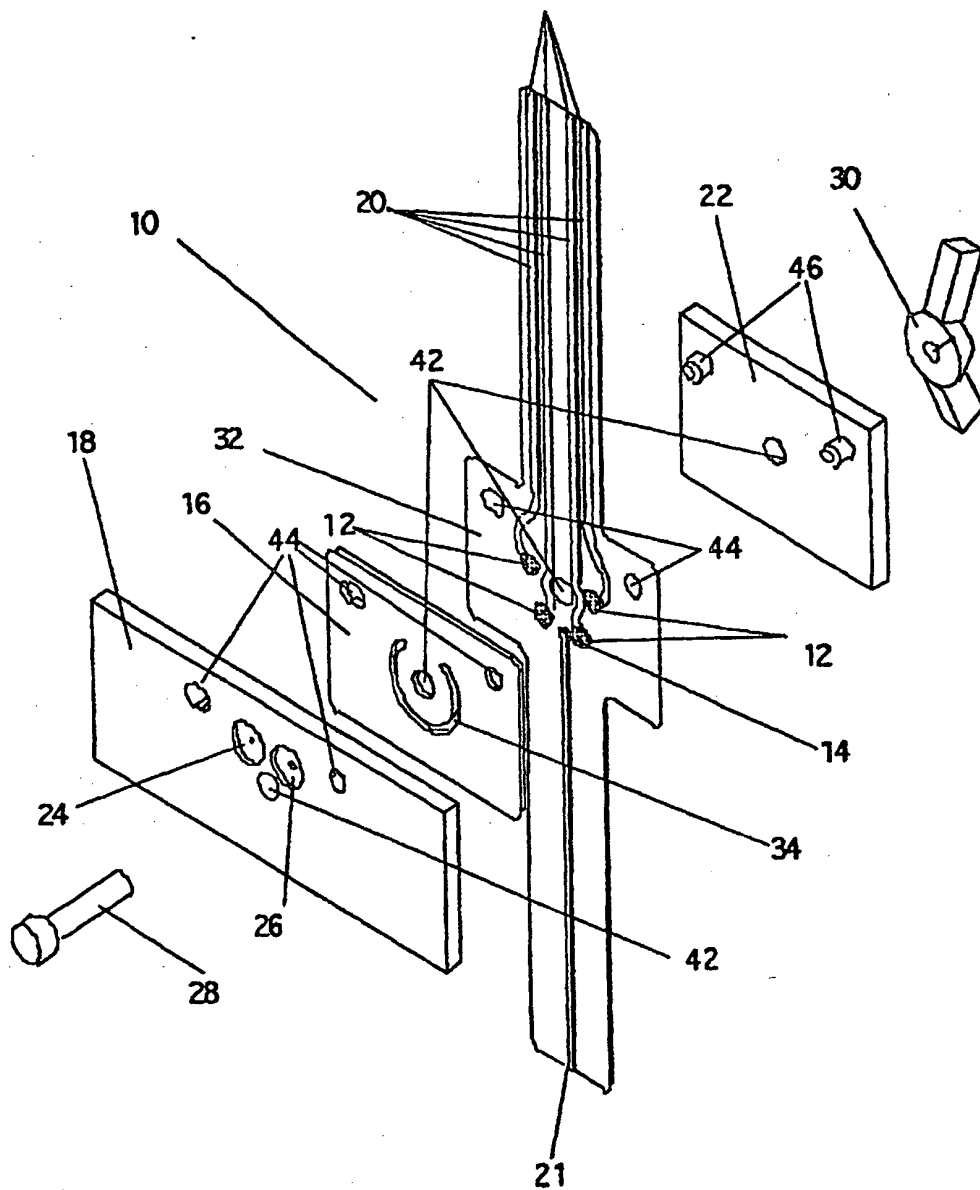

Figure 1